

O-A24HXXXXYYX-X

Low Power Consumption, Low Cost

AT-cut OCXO in miniature 20x20 mm Package

With DIL14 Compatible Pinout

Product Data Sheet

Features

- AT-cut crystal
- Low Power Consumption
- Fast Warm-up Time (2 minutes)
- Low Cost
- Hermetically sealed package
- DIL14 Pinout

Applications

- Instrumentation
- Battery powered equipment
- Telecommunication Systems
- Data Communications
- GPS
- COTS/Dual use

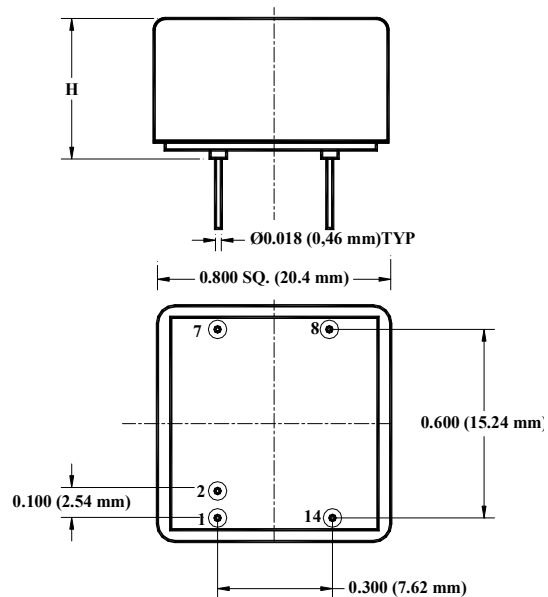
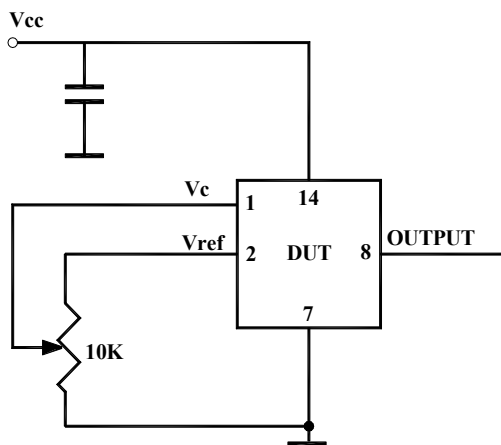

Height, H	Code
0.433ö (11 mm)	4
0.533ö (13.5 mm)	5

O-A24HXXXXYYX -X

Rev. B

Parameter	Symb	Condition	Min	Typ	Max	Unit	Note
-----------	------	-----------	-----	-----	-----	------	------

Absolute Maximum Ratings

Input Break Down Voltage	Vcc		-0.5		5.5	V	Vcc = 5 V
Storage temper.	Ts		-40		85	°C	
Operating temper.	To		-40		85	°C	
Control Voltage	Vc		-1		6	V	

Electrical (6)

Frequency	F		8.0	10.000	20.000	MHz	*
Frequency stability	ΔF/F	vs. Temp.		100		ppb	See chart below
		vs. Supply		2	5	ppb/5% Vcc	
Aging		per day		2E-9			after 30 days
		per year, first year 10 years		2E-7 1E-6			1*
Allan Deviation		.1s to 1s		5E-11			
SSB Phase Noise		1Hz		-85		dBc/Hz	2*
		10 Hz		-115	-110		
		100 Hz		-145	-140		
		1 KHz		-155	-150		
		10 KHz		-165	-160		
		100 KHz		-165	-160		
Retrace		After 30 minutes			±30	ppb	24 hrs off
G-sensitivity		worst direction		±2.0		ppb/G	
Input Voltage	Vcc		4.75	5.0	5.25	V	See chart below to specify
			3.165	3.30	3.465		
Power consumption	P	steady state, 25°C steady state, -20°C start-up		0.65	0.6	W	Still air 3*
				1.0	2.7		
Spectral Purity		Subharmonics Spurious Harmonics		none		dBc	
				-35	-30		
Load		10KOhm//15pF (HCMOS/TTL), AC-coupled 50 Ohm (Sine-wave)					Output Code T Output Code S
Warm-up time	τ	to 0.1ppm accuracy		90	120	seconds	
Output Power			+5	+7		dBm	Output Code S
Logic 1 (CMOS)	Voh		0.7 Vref			V	Output Code T
Logic 0 (CMOS)	Vol				0.1 Vref	V	Output Code T
Control voltage	Vc		0		Vref	V	4*
Reference Voltage	Vref			4.5		V	5 V supply
				3.0			3.3 V supply
Pull range		from nominal F, 10 MHz	±1.5	±2.5		ppm	5 V supply
			±1.0	±1.7			3.3 V supply
Deviation slope		Monotonic, posit. 10 MHz		1.2		ppm/V	5 V supply
				1.2			3.3 V supply
Input impedance	Zin	At Vc pin	10			KOhm	
Modulation bandwidth	Fm		DC		1	KHz	Note 8
Setability	Vc0	@25°C, Fnom.	Vref/2- 0.25	Vref/2	Vref/2 + 0.25	V	5*
Initial Calibration		Vc = Vref/2 @25°C			±250	ppb	10 MHz

All parameters for 10 MHz

O-A24HXXXXYYX -X

Rev. B

Environmental and Mechanical

Operating temp. range	-20°C to 70°C Standard, Other options ó see chart below
Mechanical Shock	Per MIL-STD-202, 30G, 11ms
Vibration	Per MIL-STD-202, 5G to 2000 Hz
Soldering Conditions	260°C for 10s Max leads only

Electrical Connections

Pin Out	Pin #1-- Vc ; Pin#2 ó Vref (optional 7*); Pin #7 ó GND; Pin #8 ó Output; Pin #14 - Vcc
----------------	--

Notes:

1. Aging rates are proportional to the operating frequency. Pull range will be adjusted accordingly to provide for lifetime possibility to set on frequency
2. Close to the carrier phase noise deteriorates with increase in frequency.
3. Power consumption listed in the table is for 10.000 MHz, Sine-wave output, 0.5ö height unit. With increase in upper operating temperature, the power consumption will increase about 60 mW per 5°C. 0.4ö units will have about 10% more power consumption.
4. If Vref is not used for adjusting the frequency, Vc range can be increased to 5.0 V with either Vcc option.
5. The Vc input may or may not be internally biased to roughly Vref/2. If internal bias is needed ó it has to be specified on PO.
6. All parameters, unless otherwise specified, are at nominal conditions, ie: T=25°C, Nominal Vcc & Nominal Load.
7. Pin 2 Vref is optional, please see part number creation.
8. Older and stock units may have MBW of 150 Hz Max.



O-A24HXXXXYYX -X

Rev. B

Creating a Part Number

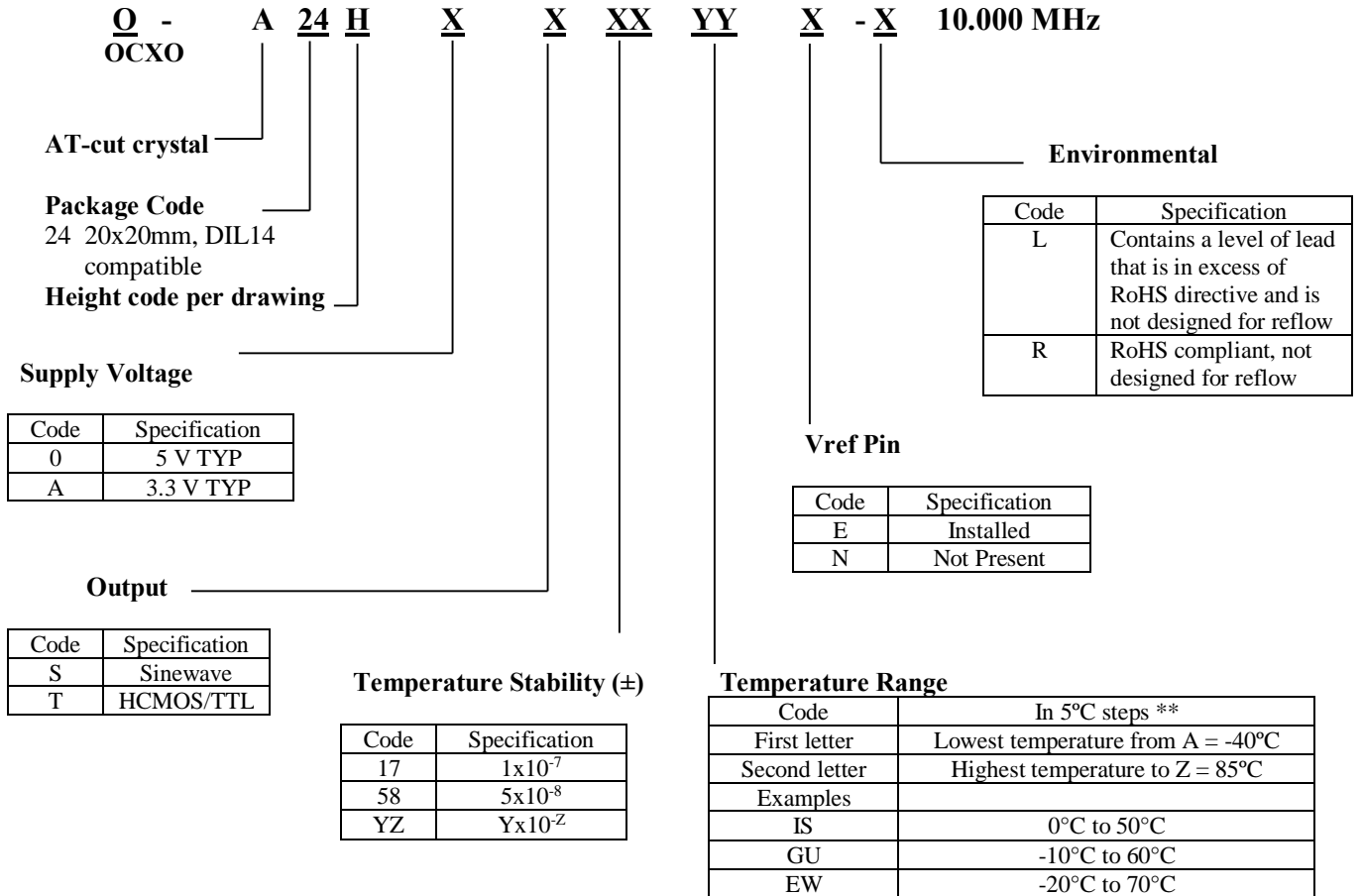

Not all combinations are available – consult factory

****Temperature Code Table**

Letter	Temp °C	Letter	Temp °C	Letter	Temp °C	Letter	Temp °C	Letter	Temp °C	Letter	Temp °C
A	-40	F	-15	K	10	P	35	U	60	Z	85
B	-35	G	-10	L	15	Q	40	V	65		
C	-30	H	-5	M	20	R	45	W	70		
D	-25	I	0	N	25	S	50	X	75		
E	-20	J	5	O	30	T	55	Y	80		